

N-Channel 150 V (D-S) MOSFET

PRODUCT SUMMARY

BV_{DSS}	150V
$R_{DSON(MAX.)}$	0.065 Ω
I_D	30A

FEATURES

- SGT technology Power MOSFETS
- 150 °C Junction Temperature
- 100 % R_g Tested

APPLICATIONS

- Primary Side Switch
- DC/DC Converter



RoHS
COMPLIANT
HALOGEN
FREE

TO-252

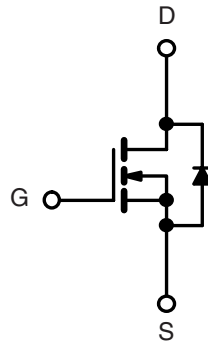
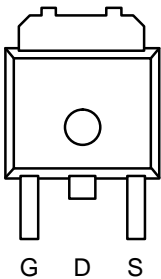

N-Channel MOSFET

Absolute Maximum Ratings ($T_c = 25\text{ }^\circ\text{C}$, unless otherwise noted)

Parameter	Symbol	Value	Unit
Drain-Source Voltage	V_{DS}	150	V
Gate-Source Voltage	V_{GS}	± 20	V
Continuous Drain Current@10V	I_D	$T_c = 25\text{ }^\circ\text{C}$	30
		$T_c = 100\text{ }^\circ\text{C}$	18.8
Pulsed Drain Current	I_{DM}	120	A
Single Pulse Avalanche Energy	E_{AS}	L = 0.1 mH	6.3
Avalanche Current			I_{AS}
Total Power Dissipation	P_D	$T_c = 25\text{ }^\circ\text{C}$	59.5
Operating Junction and Storage Temperature Range	T_J, T_{STG}	-55 to +150	$^\circ\text{C}$

Thermal Characteristics

Parameter	Symbol	TYP.	MAX.	Unit
Thermal resistance, junction-to-ambient	$R_{\theta JA}$	-	50	$^\circ\text{C} / \text{W}$
Thermal resistance, junction-to-case	$R_{\theta JC}$	-	2.1	

Electrical Characteristics $T_J = 25^\circ\text{C}$, unless otherwise noted

Parameter	Symbol	Test Conditions	Min.	Typ.	Max.	Unit
Static Characteristics						
Drain-Source Breakdown Voltage	$V_{(BR)DSS}$	$V_{GS} = 0\text{ V}$, $I_D = 250\ \mu\text{A}$	150	-	-	V
Gate-body Leakage current	I_{GSS}	$V_{DS} = 0\text{ V}$, $V_{GS} = \pm 20\text{ V}$			± 100	nA
Zero Gate Voltage Drain Current	I_{DSS}	$V_{DS} = 150\text{ V}$, $V_{GS} = 0\text{ V}$, $T_J = 25^\circ\text{C}$	-	-	1	μA
		$V_{DS} = 150\text{ V}$, $V_{GS} = 0\text{ V}$, $T_J = 100^\circ\text{C}$	-	-	100	
Gate-Threshold Voltage	$V_{GS(th)}$	$V_{DS} = V_{GS}$, $I_D = 250\ \mu\text{A}$	1.5		2.5	V
Drain-Source On-Resistance	$R_{DS(on)}$	$V_{GS} = 10\text{ V}$, $I_D = 15\text{ A}$	-	0.053	0.065	Ω
		$V_{GS} = 4.5\text{ V}$, $I_D = 12\text{ A}$	-	0.062	0.080	
Forward Transconductance	g_{fs}	$V_{DS} = 15\text{ V}$, $I_D = 15\text{ A}$	-	30	-	S
Dynamic Characteristics						
Input Capacitance	C_{iss}	$V_{DS} = 75\text{ V}$, $V_{GS} = 0\text{ V}$, $f = 1\text{ MHz}$	-	630	-	μF
Output Capacitance	C_{oss}		-	57	-	
Reverse Transfer Capacitance	C_{rss}		-	3.3	-	
Switching Characteristics						
Gate Resistance	R_g	$f = 1\text{ MHz}$	-	2.2	-	Ω
Total Gate Charge	Q_g	$V_{DS} = 75\text{ V}$, $V_{GS} = 10\text{ V}$, $I_D = 15\text{ A}$	-	9.6	-	nC
Gate-Source Charge	Q_{gs}		-	2.3	-	
Gate-Drain Charge	Q_{gd}		-	1.9	-	
Turn-On Delay Time	$t_{d(on)}$	$V_{DD} = 75\text{ V}$, $I_D \cong 15\text{ A}$, $V_{GEN} = 10\text{ V}$, $R_G = 3\ \Omega$	-	6.5	-	nS
Rise Time	t_r		-	2.4	-	
Turn-Off Delay Time	$t_{d(off)}$		-	13.9	-	
Fall Time	t_f		-	3.5	-	
Drain-Source Body Diode Characteristics						
Diode Forward Voltage	V_{SD}	$I_S = 15$, $V_{GS} = 0\text{ V}$	-	-	1.2	V
Continuous Source-Drain Diode Current	I_S	$T_J = 25^\circ\text{C}$	-	-	30	A
Reverse Recovery Charge	Q_{rr}	$T_J = 25^\circ\text{C}$, $I_F = 15\text{ A}$, $dI/dt = 100\text{ A}/\mu\text{s}$	-	58	-	nC
Reverse Recovery Time	t_{rr}		-	45	-	ns

Notes:

- Repetitive rating, pulse width limited by junction temperature $T_{J(MAX)}=150^\circ\text{C}$.
- The test condition is $V_{DD}=25\text{V}$, $V_{GS}=10\text{V}$, $L=0.4\text{mH}$, $I_{AS}=8.4\text{A}$.
- The data tested by surface mounted on a 1 inch² FR-4 board with 2OZ copper, The value in any given application depends on the user's specific board design.
- The data tested by pulsed, pulse width $\leq 300\ \mu\text{s}$, duty cycle $\leq 2\%$.
- This value is guaranteed by design hence it is not included in the production test.

Test circuit and Waveform

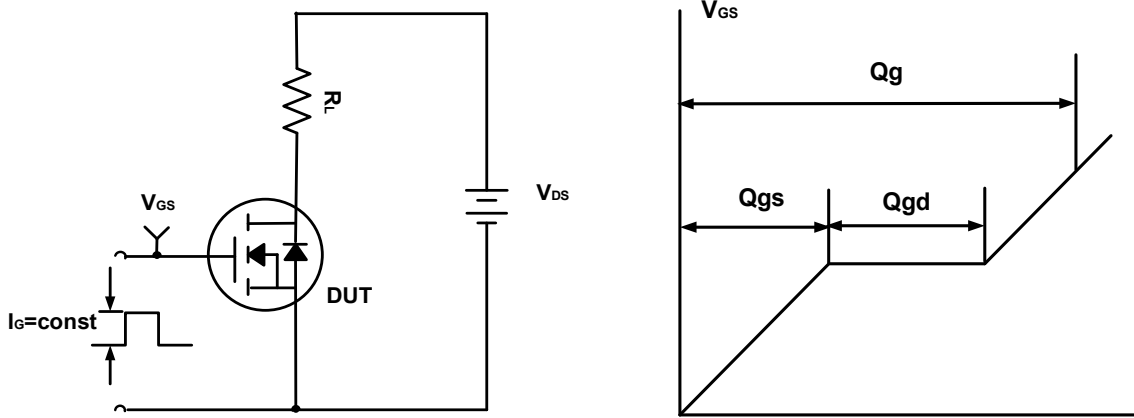

Gate Charge Test Circuit & Waveforms

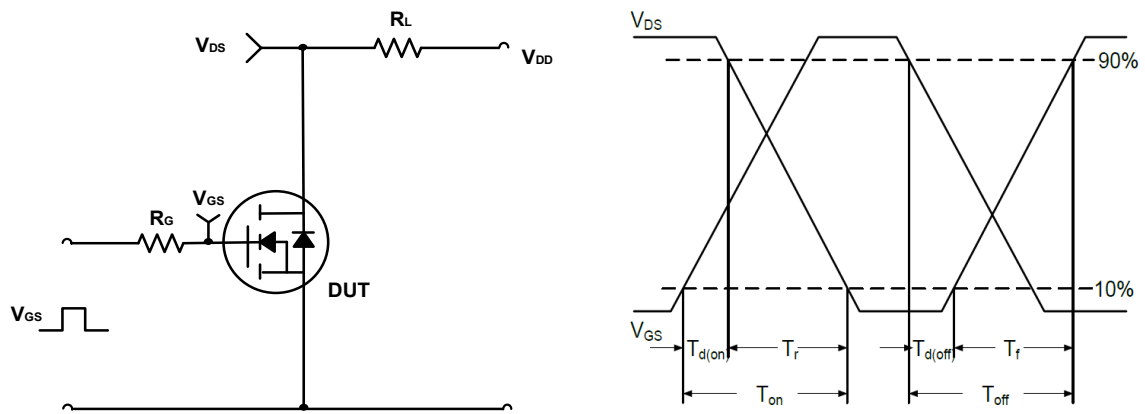

Switching Test Circuit & Waveforms

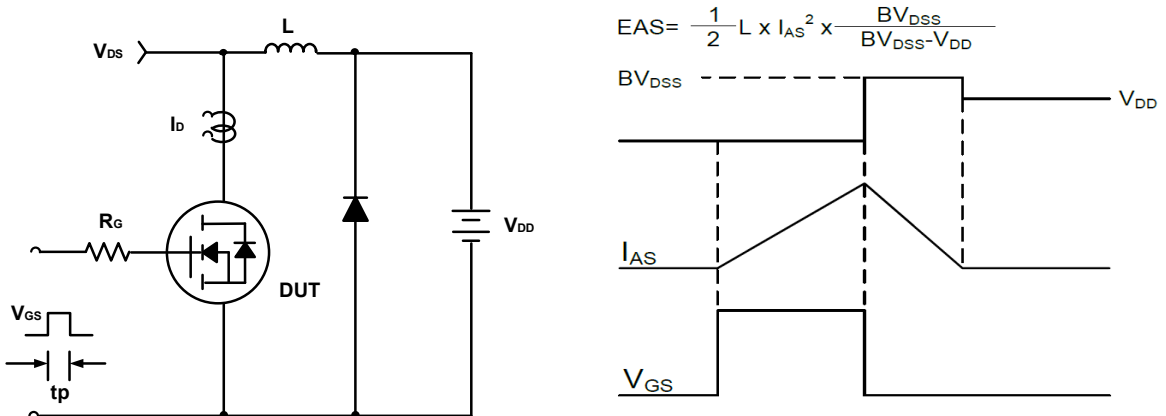

Unclamped Inductive Switching Circuit & Waveforms

TYPICAL CHARACTERISTICS (25 °C unless noted)

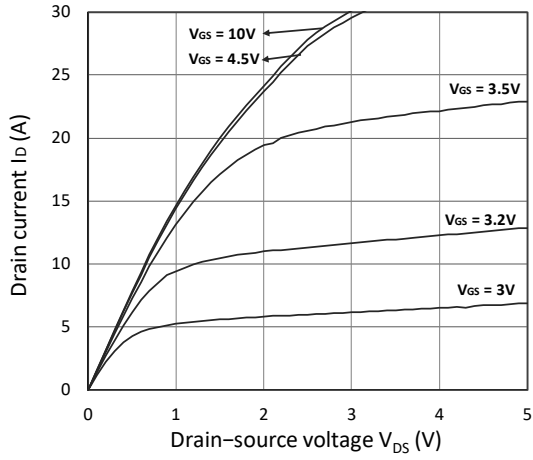

Output Characteristics

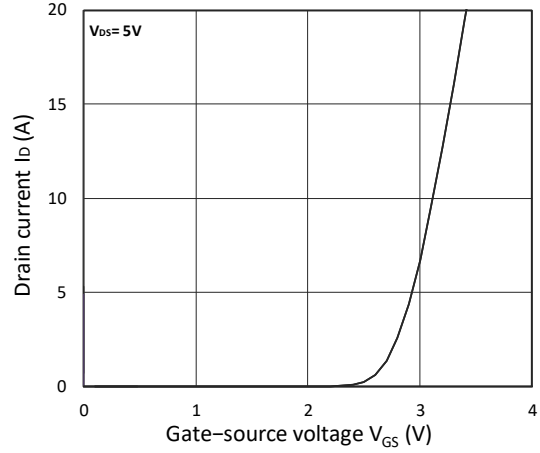

Transfer Characteristics

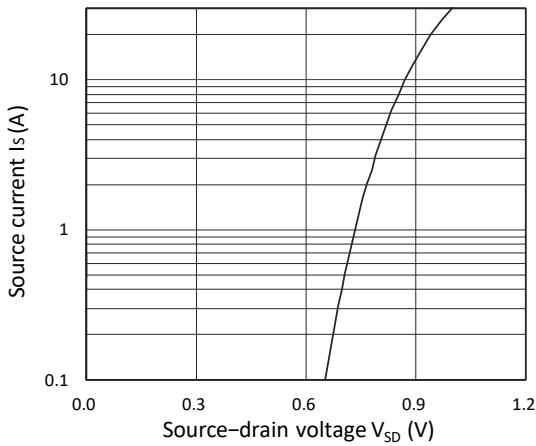

Forward Characteristics of Reverse

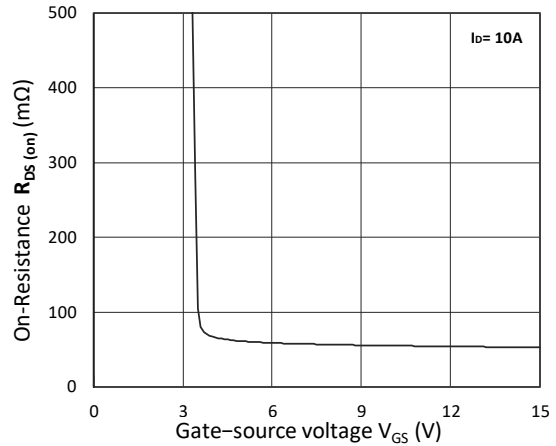

$R_{DS(ON)}$ vs. V_{GS}

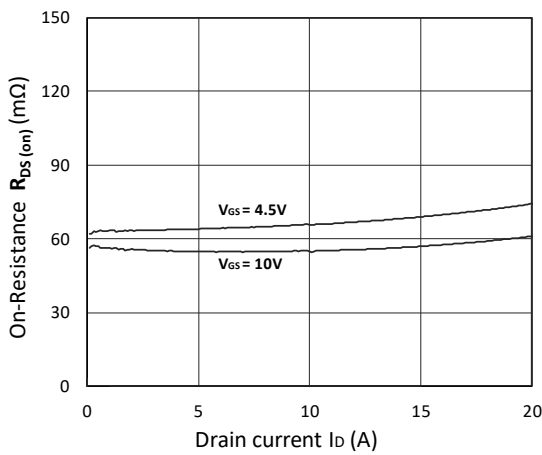

$R_{DS(ON)}$ vs. I_D

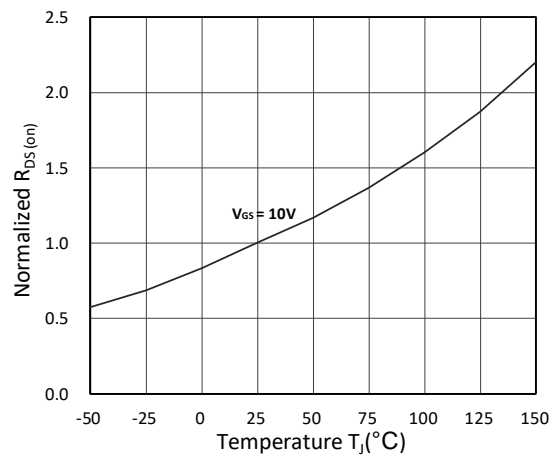

Normalized $R_{DS(on)}$ vs. Temperature

TYPICAL CHARACTERISTICS (25 °C unless noted)

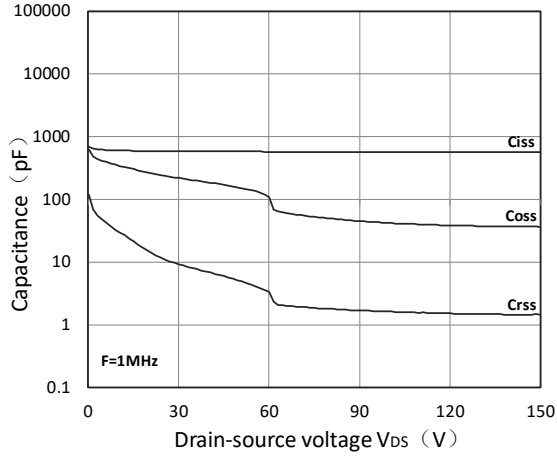

Capacitance Characteristics

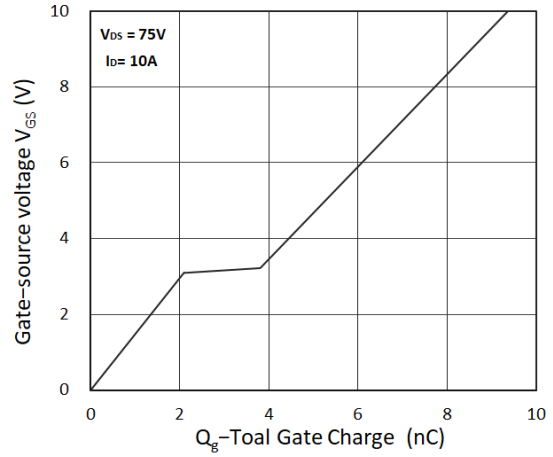

Gate Charge Characteristics

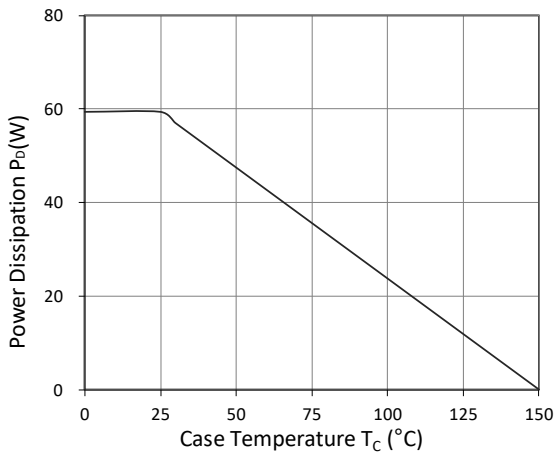

Power Dissipation

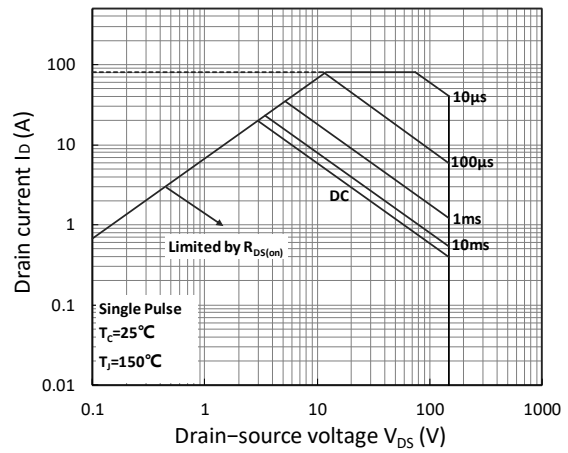

Safe Operating Area

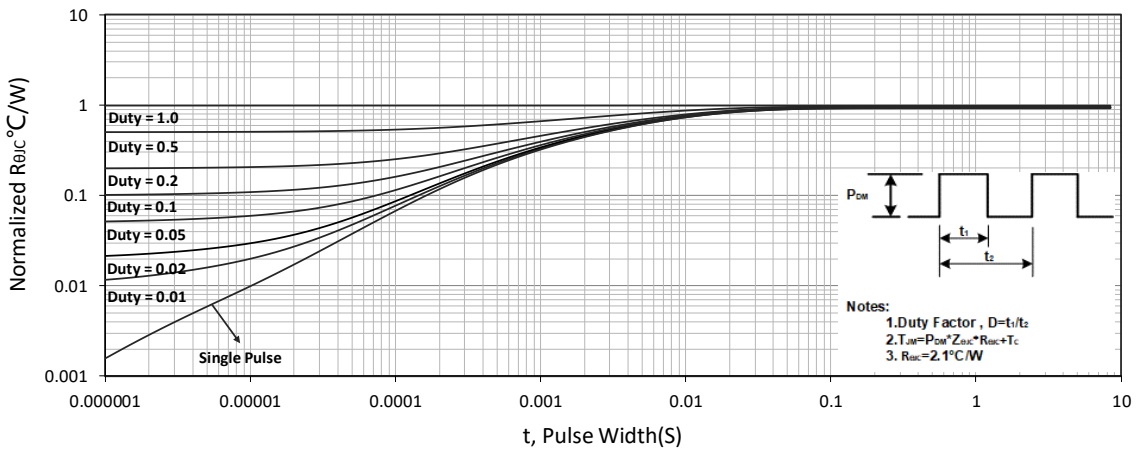

Normalized Maximum Transient Thermal Impedance

- Notes:
1. Duty Factor, $D=t_r/t_f$
 2. $T_{DM}=P_{DM} \cdot Z_{th}(j\omega) + T_C$
 3. $R_{th(jc)}=2.1^\circ\text{C/W}$

TO-252 _ PACKGE OUTLIN

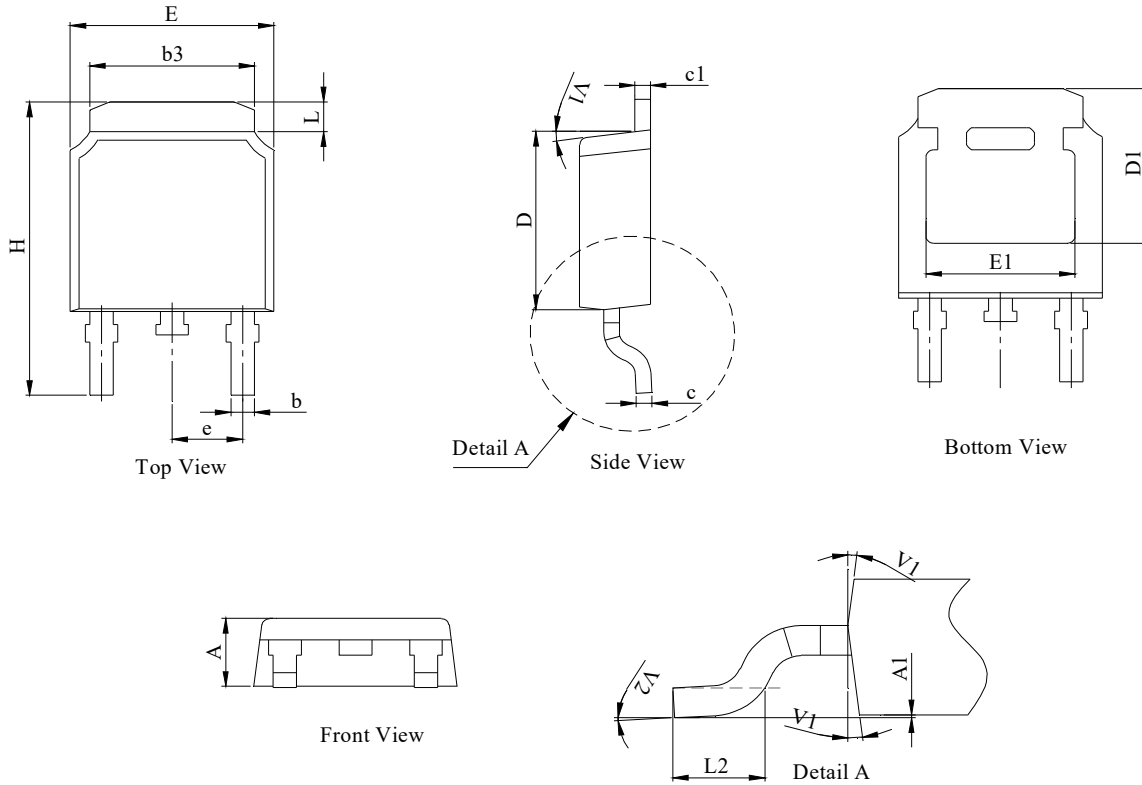

SYMBOLS	MILLIMETERS		INCHES	
	MIN	MAX	MIN	MAX
A	2.18	2.39	0.086	0.094
A1	0.00	0.13	0.000	0.005
b	0.64	0.89	0.0252	0.035
c	0.40	0.61	0.052	0.024
c1	0.46	0.58	0.018	0.023
D	5.97	6.23	0.24	0.25
D1	5.05		0.199	
E	6.35	6.73	0.250	0.265
E1	4.32	-	0.17	
b3	5.21	5.55	0.205	0.219
e	2.29 BSC		0.090 BSC	
H	9.40	10.40	0.370	0.409
L	0.89	1.27	0.035	0.050
L2	1.40	1.78	0.0551	0.0701
V1	7° REF		0.276° REF	
V2	0°	6°	0°	0.236°

Product Specification Statement

All products due to improve reliability, function or for other reasons, product specifications and data are subject to change without notice.

The product specification aims to provide users with a reference regarding various product parameters, performance, and usage. It presents certain aspects of the product's performance in graphical form and is intended solely for users to select product and make product comparisons, enabling users to better understand and evaluate the characteristics and advantages of the product. It does not constitute any commitment, warranty, or guarantee.

The product parameters described in the product specification are numerical values, characteristics, and functions obtained through actual testing or theoretical calculations of the product in an independent or ideal state. Due to the complexity of product applications and variations in test conditions and equipment, there may be slight fluctuations in parameter test values. SAILFERO shall not guarantee that the actual performance of the product when installed in the customer's system or equipment will be entirely consistent with the product specification, especially concerning dynamic parameters. It is recommended that users consult with professionals for product selection and system design. Users should also thoroughly validate and assess whether the actual parameters and performance when installed in their respective systems or equipment meet their requirements or expectations. Additionally, users should exercise caution in verifying product compatibility issues, and SAILFERO assumes no responsibility for the application of the product.

SAILFERO strives to provide accurate and up-to-date information to the best of our ability. However, due to technical, human, or other reasons, SAILFERO cannot guarantee that the information provided in the product specification is entirely accurate and error-free. SAILFERO shall not be held responsible for any losses or damages resulting from the use or reliance on any information in these product specifications. SAILFERO reserves the right to revise or update the product specification and the products at any time without prior notice, and the user's continued use of the product specification is considered an acceptance of these revisions and updates. Prior to purchasing and using the product, users should verify the above information with SAILFERO to ensure that the product specification is the most current, effective, and complete. If users are particularly concerned about product parameters, please consult SAILFERO in detail or request relevant product test reports. Any data not explicitly mentioned in the product specification shall be subject to separate agreement.

Users are advised to pay attention to the parameter limit values specified in the product specification and maintain a certain margin in design or application to ensure that the product does not exceed the parameter limit values defined in the product specification. This precaution should be taken to avoid exceeding one or more of the limit values, which may result in permanent irreversible damage to the product, ultimately affecting the quality and reliability of the system or equipment.

The design of the product is intended to meet civilian needs and is not guaranteed for use in harsh environments or precision equipment. It is not recommended for use in systems or equipment such as medical devices, aircraft, nuclear power, and similar systems, where failures in these systems or equipment could reasonably be expected to result in personal injury. SAILFERO shall assume no responsibility for any consequences resulting from such usage.

Users should also comply with relevant laws, regulations, policies, and standards when using the product specification. Users are responsible for the risks and liabilities arising from the use of the product specification and must ensure that it is not used for illegal purposes. Additionally, users should respect the intellectual property rights related to the product specification and refrain from infringing upon any third-party legal rights. SAILFERO shall assume no responsibility for any disputes or controversies arising from the above-mentioned issues in any form.